

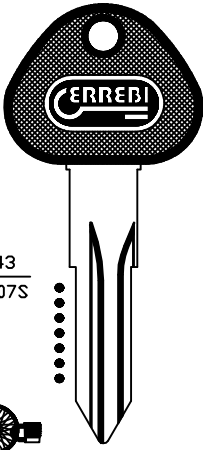









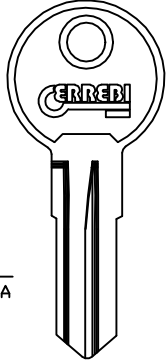

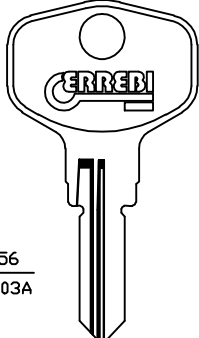

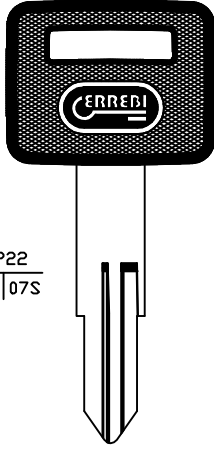

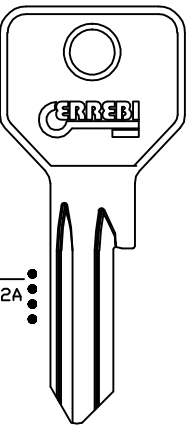

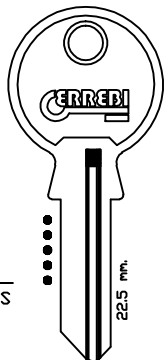

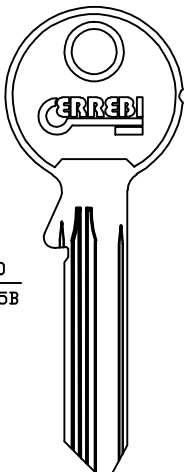
| ABUS   |  | CAB  |  | CASH BOX   |  |  |  |
|--|--|--|--|--|--|--|--|
|  <p>P43<br/>S 07S</p>  <p>Z71...1-1043<br/>Z72...1-1043</p>  <p>AU66P43<br/>BUFFO</p> |  |  <p>112<br/>B 02A</p>  <p>CAB2R</p>   |  |  <p>756<br/>S 03A</p>  <p>CSB4R</p> |  |  <p>P22<br/>S 07S</p>  <p>CSB5P22</p>             |  |
| CISA   |  | GHE  |  | MEC  |  | MLM  |  |
|  <p>-<br/>B 02A</p>  <p>30 mm.</p>  <p>C4DE<br/>ABUS-AGB-DOBUS-TZAFRER</p>           |  |  <p>266<br/>S 03S</p> <p>22.5 mm.</p>  <p>091-320</p>  <p>GX<br/>GH5T<br/>PERHAUS-POS-WECCO</p> |  |  <p>670<br/>S 05B</p>  <p>MEC1</p> |  |  <p>581<br/>S 03A</p>  <p>MLM2R<br/>DOM-STUV</p> |  |

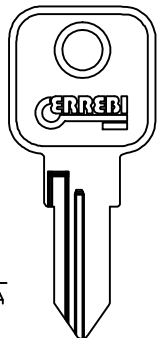
PER/FOR:

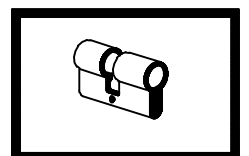
**ABUS ( D )**  
**BUFFO**  
**CAB ( I )**  
**CASH-BOX ( D )**  
**CISA ( I )**  
 ABUS  
 AGB  
 DOBUS  
 TZAFRER  
**GHE ( D )**  
 PERHAUS  
 POS  
 WECCO  
**MEC ( NL )**  
**MLM ( D )**  
 DOM  
 STUV

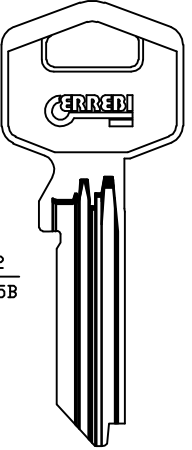
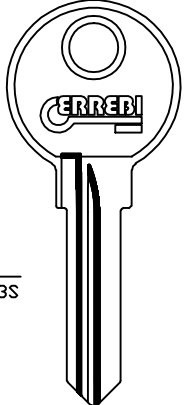
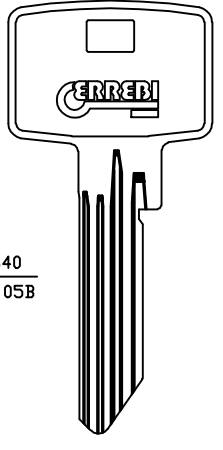

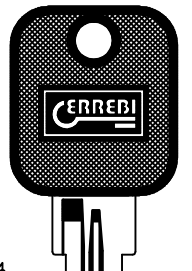
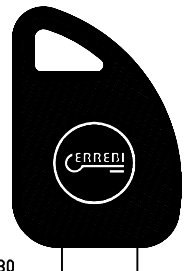
1

| NEMEF   | OJMAR  | PFAFFENHAIN   |  |
|---|--|---|--|
|  <p>232<br/>S 05B</p> <p>NF1    NF2</p> |  <p>-<br/>S 03S</p> <p>OJ24R</p>                     |  <p>640<br/>S 05B</p> <p>A23</p> <p>PH27</p>                          |  |
| AXA   | SISPA  | TOK-TRELOCK   | YWS  |
|  <p>P3<br/>S 20A</p> <p>AX6RP3</p>     |  <p>P34<br/>B 20A</p> <p>SIA6RP34<br/>AUTOBLOCK</p> |  <p>P130<br/>S 20A</p> <p>TK39P130</p> <p>TESTA ROSSA \ RED HEAD</p> |  <p>P172<br/>S 20A</p> <p>YW1P172</p> |

PER/FOR:



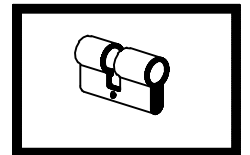

**NEMEF (NL)**  
**OJMAR (E)**  
**PFAFFENHAIN (D)**

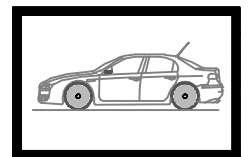

PER/FOR:

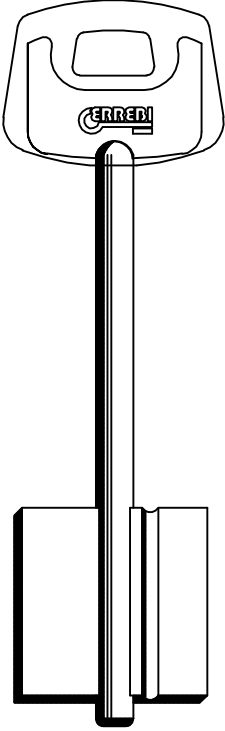
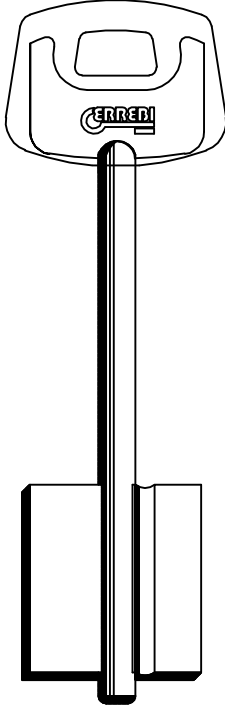
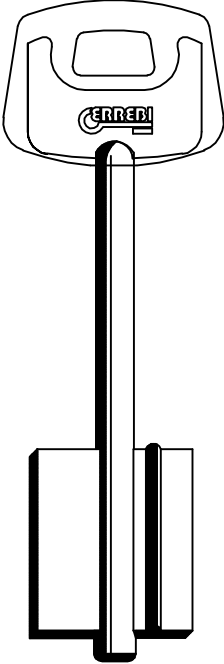
**AXA (NL)**  
**SISPA (I)**  
**TOK-TRELOCK(D)**  
**YWS (TW)**









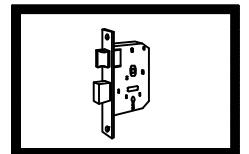

| POTENT  |   | SECUREMME   |
|---|---|---|
|    |   |   |
|  |  |  |
| CK-2PN15  | CK-2PN17  | CK-2SEM8  |

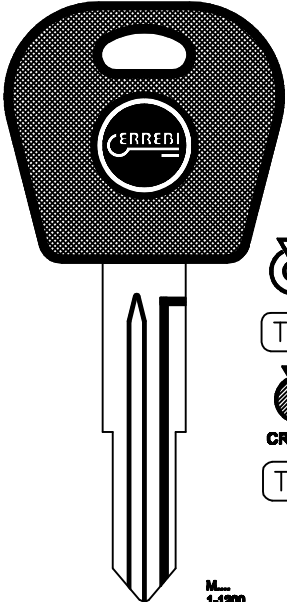
PER/FOR:

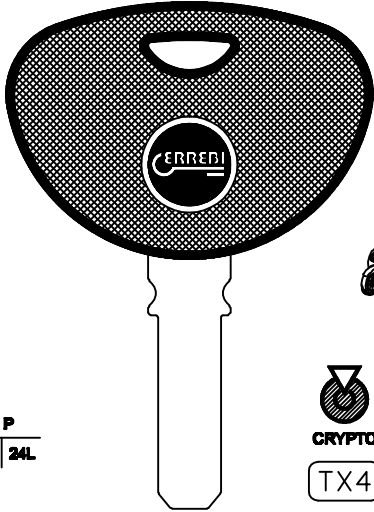
**POTENT (1)**

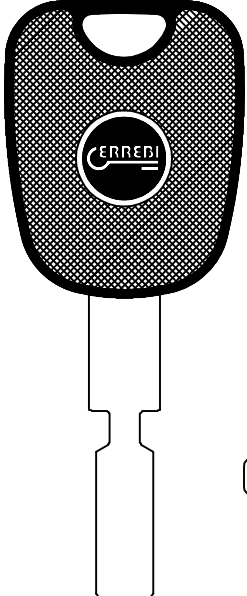
**SECUREMME (1)**

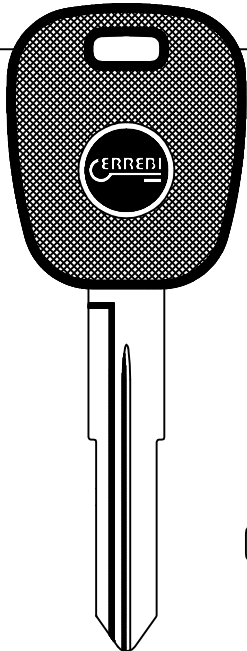

|  |   |
|--|---|
| <p style="text-align: center;">DAEWOO</p>  <p style="text-align: center;"> <br/>             T02<br/> <br/>             CRYPTO<br/>             T08 DW2P         </p> <p style="text-align: center;">             P<br/>             B   24A<br/>             24C         </p> <p>DAEWOO <span style="float: right;">ML 1-1200</span></p> | <p style="text-align: center;">HUF</p>  <p style="text-align: center;"> <br/>             CRYPTO<br/>             TX4 HF71P         </p> <p style="text-align: center;">             P<br/>             B   24L         </p> <p>BMW</p>         |
| <p style="text-align: center;">HUF</p>  <p style="text-align: center;"> <br/>             CRYPTO<br/>             TX2 HF72P         </p> <p style="text-align: center;">             P<br/>             N   24K         </p> <p>SCANIA</p>   | <p style="text-align: center;">NISSAN</p>  <p style="text-align: center;"> <br/>             CRYPTO<br/>             TX4 NS11RP         </p> <p style="text-align: center;">             P<br/>             B   24L         </p> <p>SUZUKI</p> |

**PER/FOR:**  
 DAEWOO (ROK)  
 HUF (D)  
 NISSAN (J)

