

ABUS	AUNO	CISA	DIERRE
 <p>333 B 06B</p> <p>AU91L</p>	 <p>875 B 06A</p> <p>AUN1R ANTONIOLI</p>	 <p>349 B 05A</p> <p>R021 C56</p>	 <p>374 B 06A</p> <p>DR1</p>
DIERRE	GEGE	JUNGHEINRICH	KESO
 <p>- B 06A</p> <p>DR2</p>	 <p>12 B 05B</p> <p>GG46 GG47 GG48</p>	 <p>- S 03S</p> <p>JR1R</p>	 <p>- N 06A</p> <p>KC4</p>

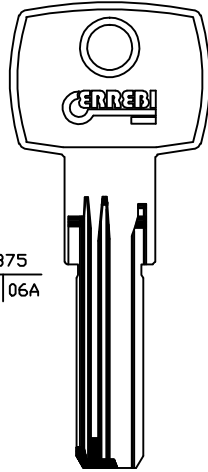

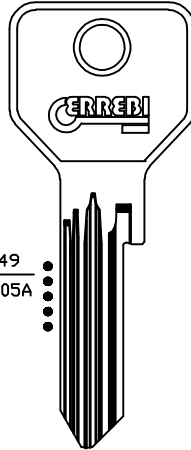

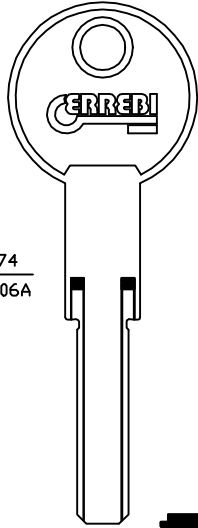
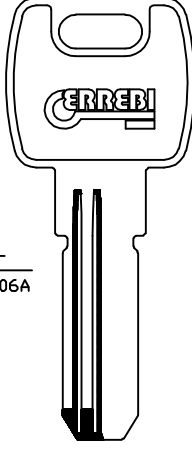
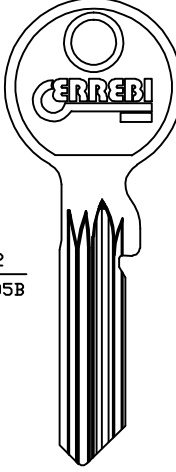
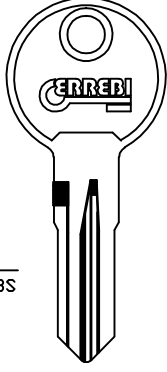
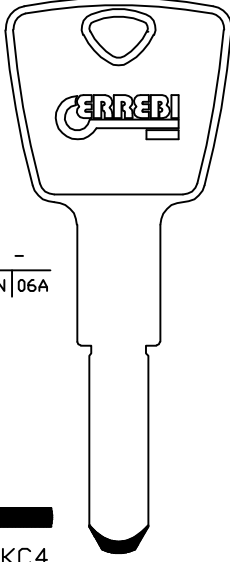
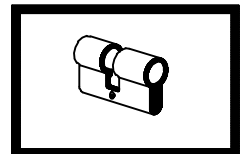

**PER/FOR:**

- ABUS (D)**
- AUNO (I)**
- CISA (I)**
- DIERRE (I)**
- GEGE (A)**
- JUNGHEINRICH (D)**
- KESO (CH)**

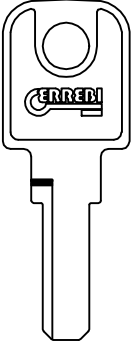

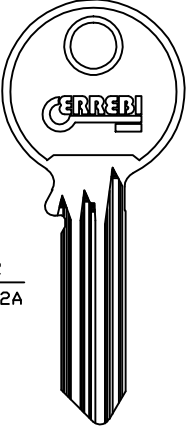
# CERREBI NEWS

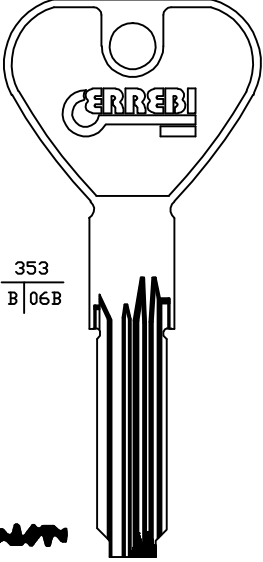
**03**  
2011

MERONI	P.C.(Cortellezzi)	TITAN
 <p>376 B 02A</p>  <p>MR33</p>	 <p>12 S 02A</p>  <p>PA11R</p>	 <p>353 B 06B</p>  <p>TT21</p>

PER/FOR:

**MERONI (I)**  
**P.C. (I)**  
**TITAN (SLO)**

CERREBI

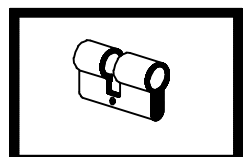

2

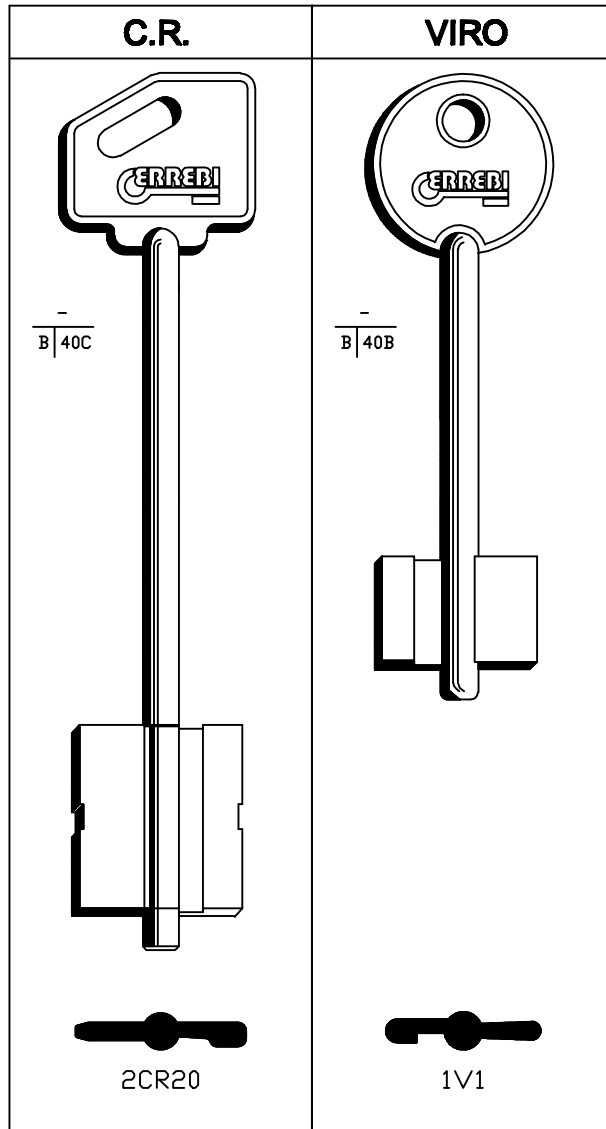

PER/FOR:



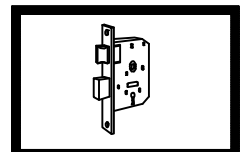

C.R. (1)  
VIRO (1)



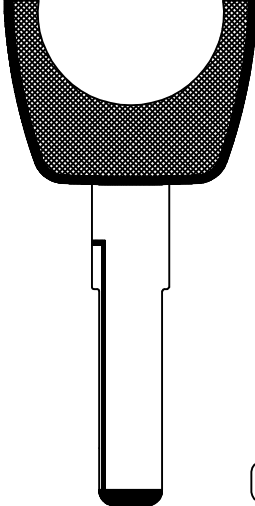

3

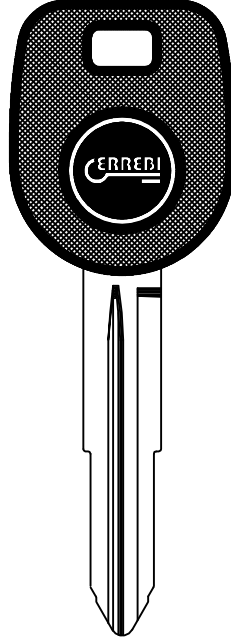
PER/FOR:

HUF ( D )  
 MITSUBISHI ( J )  
 TIBBE ( D )

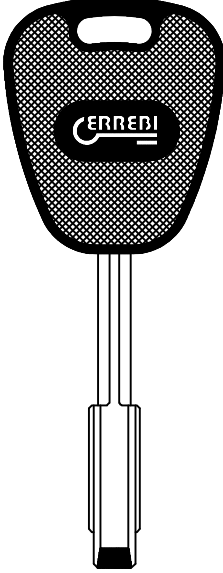
HUF	MITSUBISHI
 <p data-bbox="135 918 199 974"> <math>\frac{B}{B \mid 23M}</math> </p>  <p data-bbox="470 963 550 1008">T00</p>  <p data-bbox="470 1086 630 1131">T00HF55PB</p>	 <p data-bbox="758 918 821 974"> <math>\frac{P}{B \mid 24K}</math> </p>  <p data-bbox="1093 940 1173 1008">             CRYPTO              TX2         </p>  <p data-bbox="1093 1086 1252 1131">TX2MIT7PB</p>
HUF	MITSUBISHI

TIBBE
 <p data-bbox="135 1724 199 1780"> <math>\frac{P}{N \mid 24K}</math> </p>  <p data-bbox="470 1747 550 1814">             CRYPTO              TX2         </p>  <p data-bbox="454 1892 582 1937">TX2TB4P</p>
TIBBE

